

For Models ▶ 9067, 9067L, 9067S, 9069, 9069S

Description ▶ 180mm/230mm Angle Grinders

CONCEPTION AND MAIN APPLICATIONS

These models are angle grinders of wheel size 180mm/230mm(7"/9") designed as economy type of sister models of Model 9047/9049 series.

By suppressing maximum output of motor, Torque limiter is not necessary for these models.

Model 9067S/ 9069S are with soft start function versions of Model 9067/9069.

Model 9067L is low speed version of Model 9067.

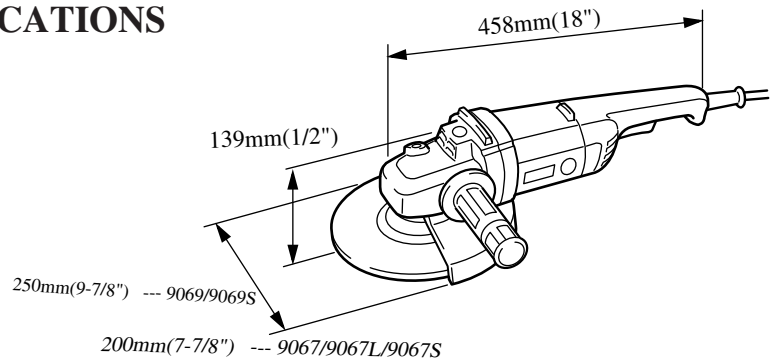

► Specifications

Voltage (V)	Current(A)	Cycle(Hz)	Continuous Rating(W)		Max. output(W)
			Input	Output	
115	15	50/60	1650	900	2600
220	9.6	50/60	2000	1100	2900
230	9.2	50/60	2000	1100	2900
240	8.8	50/60	2000	1100	2900

No load speed	9067/9067S	8500 rpm
	9067L/9069/9069S	6600 rpm
	9067L/9069	6000 rpm (for only U.S.A. and Canada)
Depressed center wheel	9067/9067L/9067S	Outer dia.:180mm(9") X Arbor dia.:22.23mm(7/8") X Thickness:6mm(1/4")
	9069/9069S	Outer dia.:230mm(9") X Arbor dia.:22.23mm(7/8") X Thickness:6mm(1/4")
Net weight	4.2Kg(9.3lbs)	
Cord length	2.5m(8.2ft)	

► Standard equipment

Lock nut wrench 35

Lock nut wrench 28 (9067L/9069: for only U.S.A. and Canada)

<Note> The standard equipment may differ from country to country.

► Optional accessories

9067/9067L/9067S	Super Flange, Depressed center wheel 24P/36P, Inner Flange78 (for cutting wheel), Outer Flange78 (for cutting wheel) Wire Cup Brush 110 , Grip set (loop handle)
9069/9069S	Super Flange, Depressed center wheel 24P/36P, Inner Flange 78 (for cutting wheel), Outer Flange78 (for cutting wheel) Wire Cup Brush110, Grip Set (loop handle)

► Repair

1. Replacing Spiral bevel gear (in replacing, if there is a trouble in Ball bearing, it should be replaced too)

- 1) Remove Depressed center wheel and Wheel cover.
- 2) Remove Tapping screw CT5x16 fixing Bearing box.

Disassemble or assemble as the following illustrations;

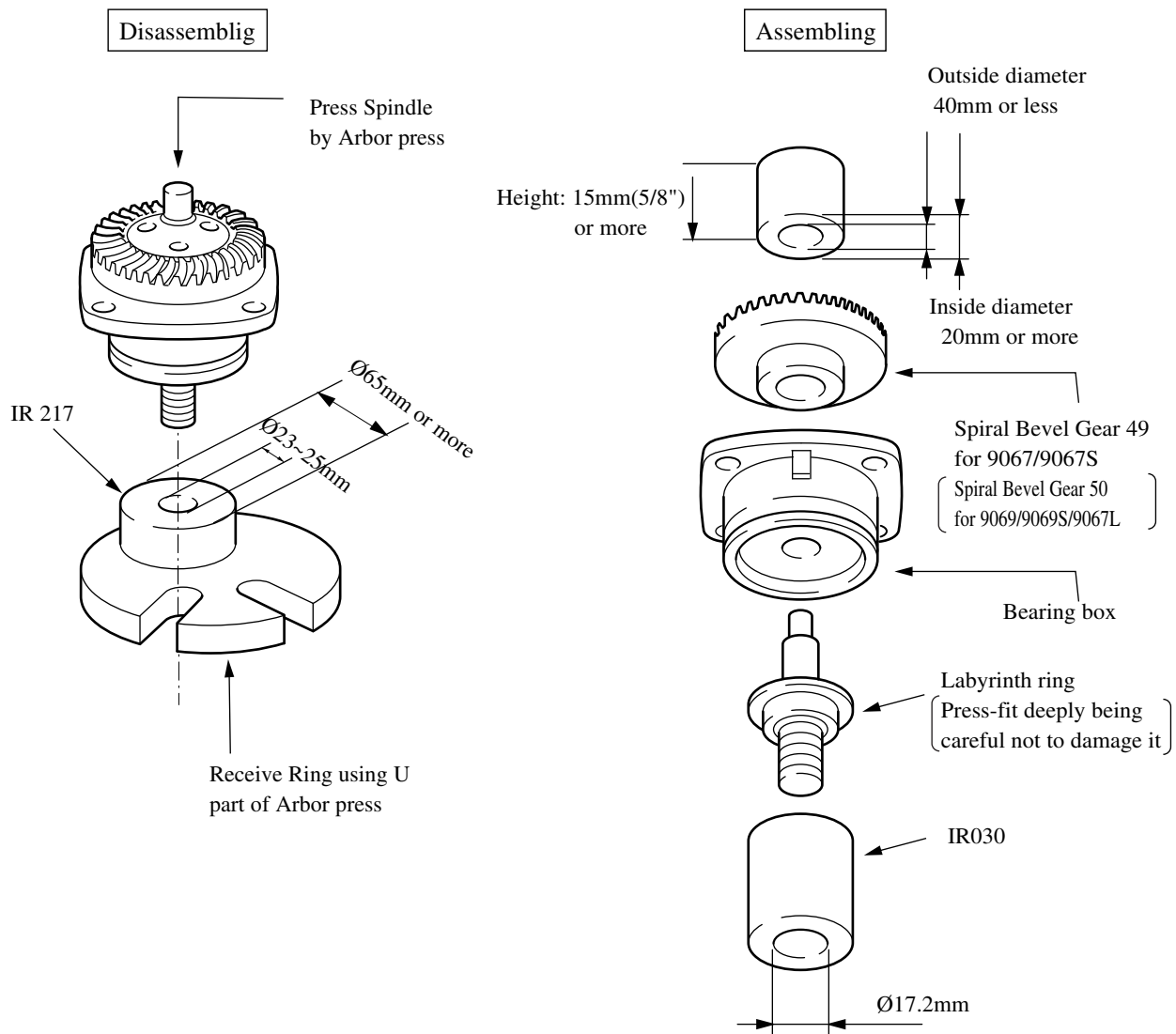

2. Assembling of Bearing box

When assembling, be careful so that grease may not stick to Tapping screw bind CT5x16.

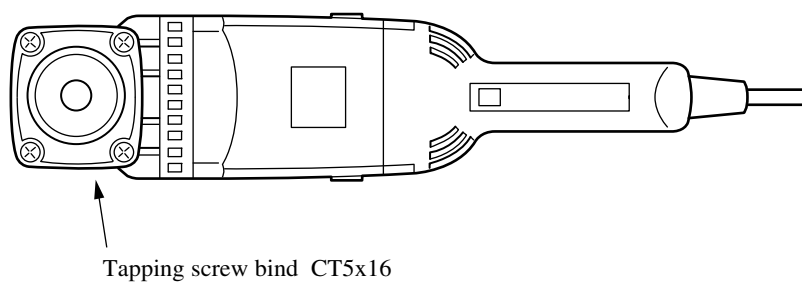

3. Replacing Armature

- 1) Remove Depressed center wheel and Wheel cover.
- 2) Remove Carbon brushes.
- 3) Remove Tapping screws fixing Gear housing and Motor housing.

